



American Legend Aircraft Company
1810 Piper Lane
Sulphur Springs, Texas 75482
903-885-7000
<http://legend.aero>

SERVICE BULLETIN

American Legend Aircraft Company considers compliance mandatory

Notification Number	SB-22-10-6
Subject	Fuel Line Support Clamp Verification
Supersedes Notices	
Release Date	October 6, 2022
Effective Date	October 6, 2022
Required Corrective Action	One Time Verification
Affected Make	American Legend Aircraft
Affected Models	AL3 – 2018 or later, AL18 -All
Affected Serial Numbers	ALL

Service to be performed by: The holder of a mechanic certificate with airframe or powerplant rating(s), or both, or a LSA Repairman.

Tools required: Common hand tools.

It has been found that the 2 aft main fuel lines, at both sides of the passenger seat could get pushed downward and come in contact with the rudder cable, due to a missing support clamp (see detail on fuel line installation drawing 150-PP0101. If the clamp is missing, install clamp as indicated. Also, examine the lines to ensure the clamps securely support the line and for signs of chafing or rubbing from the rudder cables. Replace fuel lines that show indications of chafing.

Kits containing this material can be ordered from American Legend Aircraft Company. Kit part number SB-22-10-6, 1 Each of the following. Bolt AN3-4A, Washer(s) AN960PD10, AN960PD10L, and Adel clamp MS21919WDG6.

It will be the responsibility of the owner/operator to comply with all released SAFETY ALERTS, SERVICE BULLETINS, NOTIFICATION and Airworthiness Directives as applicable. All inspection procedures and maintenance schedules must be accomplished per the manufacturer's recommendations.

For more information, please contact us at the above address or by E-mail at Randi@legend.aero

NO.	NOTES
1	DEBUR ALL SHARP EDGES
2	LINES ARE TO BE CONTINUOUS IN SLOPE AS SHOWN. AVOID LOW CONTOURS THAT COULD COLLECT WATER AND DEBRIS. LINES ARE TO PICK UP SUPPORT CLAMP POINT LOCATIONS AS SHOWN. FLARED ENDS ON FUEL TUBING ARE 37°. THEY MUST HAVE NUT AND SLEEVE ON EACH ONE. BEADED ENDS ARE PER MS33660 TYPE A. FUEL HOSE CLAMPED TO TUBING IS MECHANICALLY SECURED WITH A BEAD AND CLAMP.
3	[SEE DETAILS J AND K ON SHEET 2 THIS DRAWING]
4	VIEW SHOWS TOP ANGLE OF ELBOW TO S/O VALVE. ASSEMBLE AND SET ANGLE BEFORE INSTALLING VALVE ONTO SUPPORT BRACKET.

REV.	DESCRIPTION	DATE	APPR.
C	SECTION AB ADDED TO PULL FUEL LINE OUTBD TO INTERIOR PANEL	11/20/2011	RST/ORH

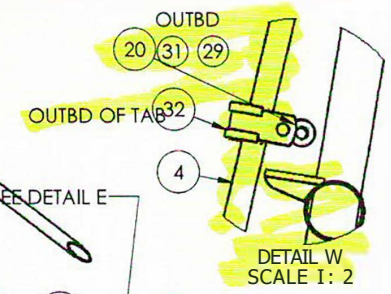
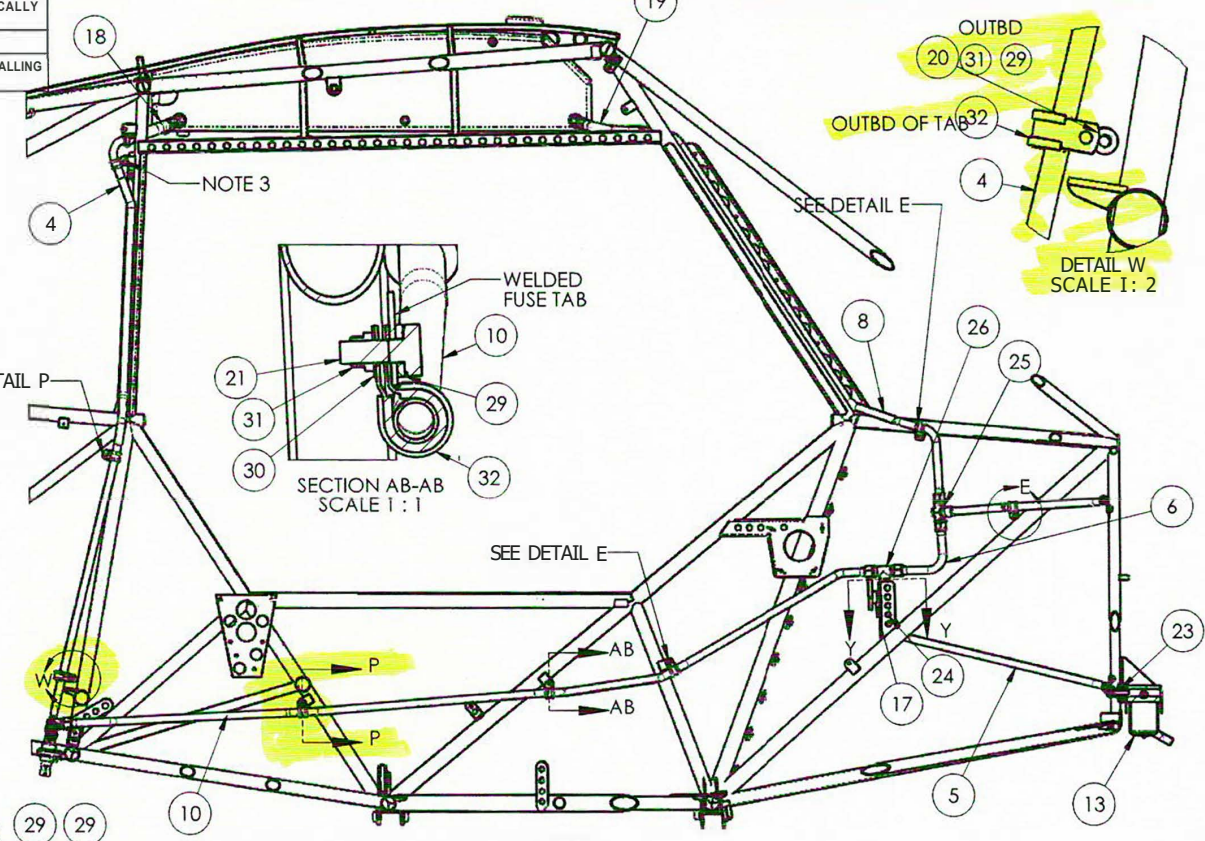
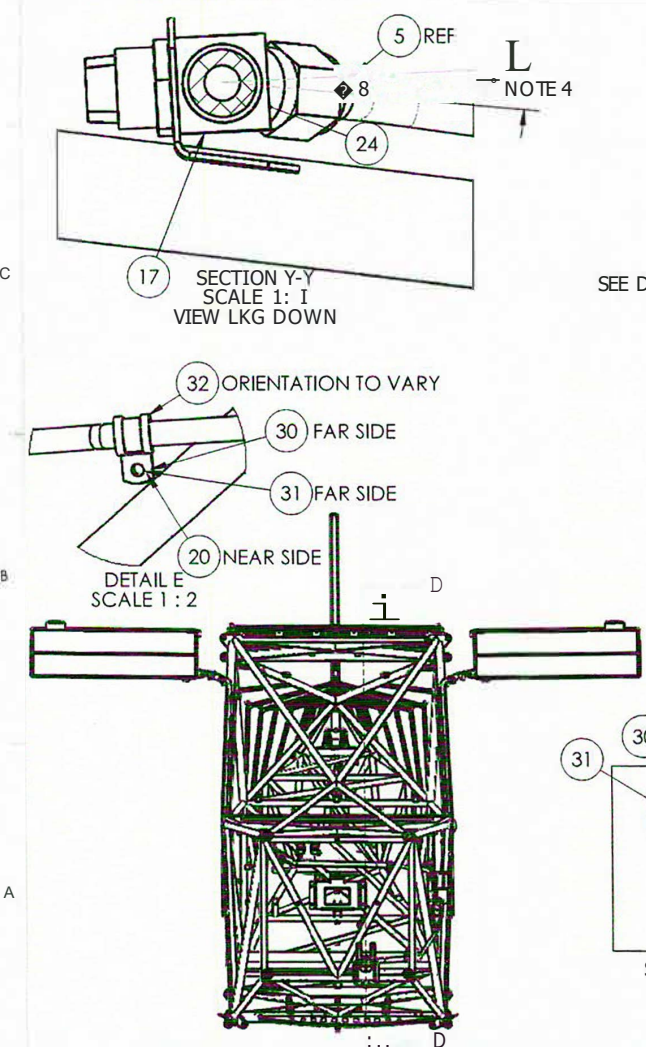

UNLESS OTHERWISE SPECIFIED:		NAME	DATE	AMERICAN LEGEND AIRCRAFT COMPANY SULPHUR SPRINGS, TEXAS TITLE: FUEL LINE INSTALLATION - AL18
ORAWU	IST	4/3/73		
CHECLED	CRH	11/13/2011		
ENGAPTR	RST	11/13/2011		SIZE PART NO. 8 150-PP01 01
PIMARF:		NASS23 RIVET CODE		REV C
MATCHING N/A		ORAWU		SCALE: 1:10 WEIGHT: 110.35 LBS SHEET OF 6

C:\Users\Bob\Documents\Legend Aircraft\Legend Engineering\VR-Rel Drawings & Lockup\Release Drawings\Power, P n l